

# INTELLIGENT APPLICATION AT THE 400/120 KV SUBSTATION OF THE PAKS NUCLEAR POWER PLANT

János Nacsa, George L. Kovács, Sándor Kopácsi

CIM Research Laboratory, Computer and Automation Research Institute,  
Hungarian Academy of Sciences, www.sztaki.hu  
nacsa@sztaki.hu

**Abstract** - A complete reconstruction program was started at the electrical substation of the Paks Nuclear Power Plant to assist the Hungarian high voltage network to join the European network. At the operator level a new, PC-based SCADA (Supervisory Control and Data Acquisition) system was introduced. An AI-based, intelligent advisory system was developed and embedded into the SCADA system. The first part of the paper shows the substation and the hardware-software environment of the intelligent system. The second part describes the advisory functions and their realizations in rules and procedures. Besides increasing reliability and safety of energy supply the basic goal of the system is to assist the operator in faster and more effective reactions if something irregular happens at the substation, and to assist the plant engineer to better understand and evaluate what was happening.

**Keywords:** power plant, intelligent systems, expert systems, SCADA, high voltage substation

## I. INTRODUCTION

One of the most important strategic aims of the Hungarian Power Companies Ltd. (MVM Rt.) is to implement an operational model of the Hungarian power system (see Fig.1.) in compliance with the standards and

practices of the European Union (EU). To fulfil this aim, power plant modernization is the most critical and complicated task. Within this task there is an information technology project known as the Hungarian Electric Board's Operational-System's Technical Modernization (ÚRIK) project. A new, computer network based communication system was established among the power plants, the substations and the electricity supply companies.

Many efforts have also been made locally at the various substations to provide data acquisition and control facilities for this project. Often the whole local operational environment had to be replaced. This was the case at one of the most important power plants in Hungary; the Paks Nuclear Power Plant located in the middle of the country on the river Danube. In 1998 Paks produced 38.0 percent of domestic electrical energy production (36787 GWh) [1]. At the substation operator level a PC-based SCADA (Supervisory Control and Data Acquisition) system was installed. With this new information system [2] the operators got a better understanding of their substation and a more precise measurement of transient events.



(Notes: English-language names of neighboring countries are Croatia (Horvátország), Slovenia, Austria, Slovakia, Ukraine, Romania and Serbia. *Paksi E.* is the Paks nuclear power plant. In the table, transmission line lengths at each voltage level are given.)

Figure 1. The Hungarian electricity network

The management decided that together with this reconstruction of the operator information system, it

would be valuable to establish an intelligent advisory system to support the operators and the plant engineers

with special expert information and knowledge. Similar efforts are running in Budapest as well [9].

The idea of applying expert systems to combine human knowledge with computerized tools is not new in the field of electrical energy. Several attempts were done worldwide (for example see [5, 6, 7, 8]), and in Hungary (mostly by DYNADATA Ltd. [9]) to use expert knowledge processing in different parts of electrical energy systems. This paper summarizes the problems and the results of our Paks substation project, which is different from all previous efforts, and it presents the substation itself and the different intelligent functions and finally implementation issues will be discussed..

## II. THE 400/120 KV SUBSTATION

Fig.2 shows the topology of the substation that has “fields” at each of the three available voltage levels.

On the top of the figure there are 16 and 120 kV fields and on the bottom right part are the five 400 kV

fields. On the bottom left can be seen the transformer field that contains two transformers and an 18 kV feeder. The four, 400 kV fields at the lower right part of the figure receive power from the generators of Paks’ four nuclear units. At the bottom of the figure there are four, 400kV lines which are part of the Hungarian backbone electricity net. The 120 kV fields supply power to cities nearby and can also feed power back to the nuclear units when it is necessary to restart a unit after a shutdown.

The basic switching elements of the substation are the circuit breakers (squares on the figure) and the line and ground disconnectors (circles). The circuit breakers can switch high currents, while the disconnectors are used to isolate portions of the substations from high voltage or securely connect parts of the substations to ground. The operator remotely switches most of these elements but in case of short circuits or other disturbances, protective relays automatically open or close the circuit breakers to keep other equipment safe.

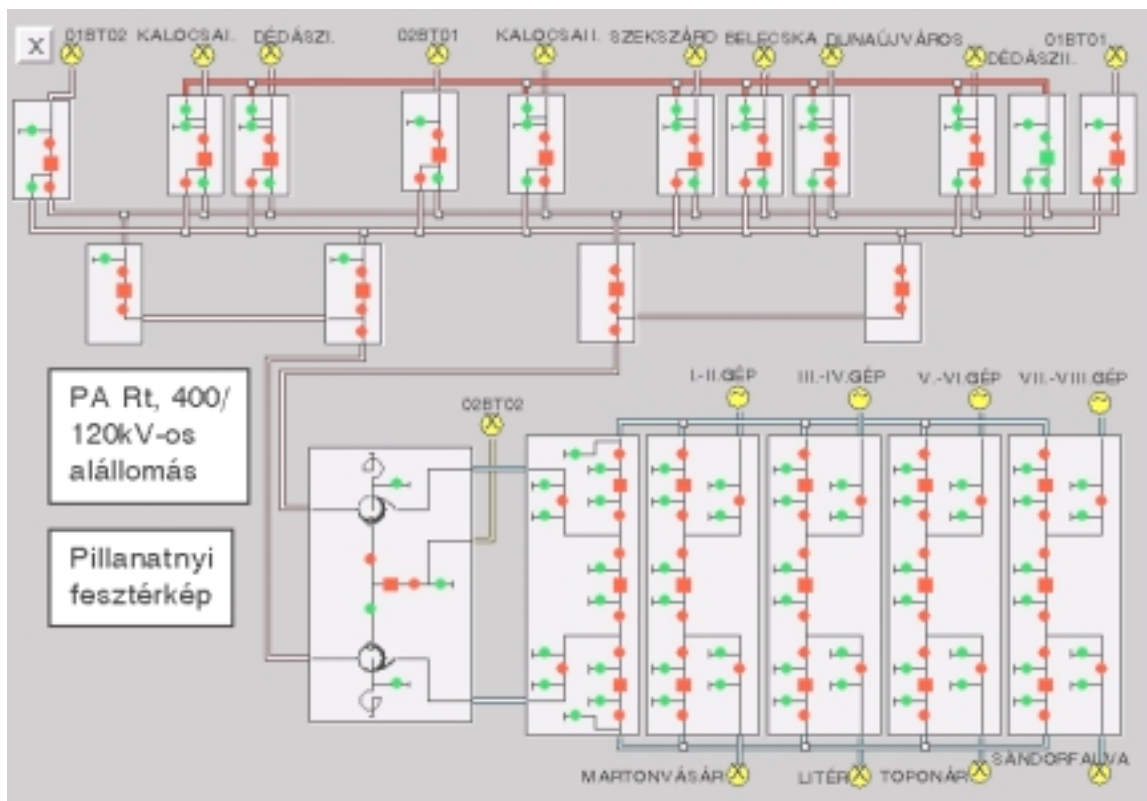

Figure 2. The topology of the 400/120 kV substation showing “instantaneous voltages”

## III. INTELLIGENT FUNCTIONS

The requirement specification of the project identified the following needs and problems in the substation from the management and organizational point of view:

- The management wanted an intelligent advisory system to support the operators with the know-how of the engineers, especially in alarm situations.
- To reduce maintenance costs and to assist maintenance design it is valuable to collect the switching information and operational history of all

types of equipment (how many times did a circuit breaker switch, and why, when and how did it switch).

- The management wanted a better understanding of the technology to compare theoretical protection sequences with the actual performances of the equipment.
- Plant engineers need effective assistance in better understanding some error/disturbance events in the substation and they need support in recovery and some other design tasks (as for example switching sequence design).

To fulfill the requirements, a multifunctional system was designed to be deeply integrated into the SCADA system and its environment. One complex system had to be developed where the various SCADA and intelligent functions could share data. The implementations of the functions were different, with rule- and procedure-based technologies mixed according to the types of functions and their timing requirements.

Two types of users were defined. The first is the operator of the substation, who gets simple warnings if any of the functions detect a problem; and the second is the electrical engineer (plant engineer) who can get various statistics about the substation and can use the data as needed, e.g. to plan future maintenance.

Finally the following intelligent functions were defined and implemented in frames of the project:

#### *A. Topology analysis with voltage and current map generation, and determination of dangerous topologies*

The SCADA system provides measurements of many voltage and current values at various points of the substation. The number of these values allows generating an actual voltage and current map for the operator. This calculation is done periodically and the system also determines whether any parts of the substation are close to a dangerous state or not. Often, the present topology and some secondary signals together can indicate an alarm situation that is very difficult for a human operator to recognize (e.g. oil pressure instability when only one transformer is on).

#### *B. Equipment diagnostics and maintenance design based on the switching types of the different items of switchgear (closed, open, trip)*

Before the new SCADA system was implemented only the catalog data were available; there was no information on actual performance. This function monitors the switching actions of all equipment and calculates various features, e.g. the slowest and the quickest switching time, deviation, average etc. It compares this information with the catalog data and if necessary warns the operator. It also examines the conditions of the switches and classifies them according to the performance of each. The result of the classification is compared with the catalog data to provide maintenance data about the aging of the equipment. At Paks this is very important information because maintenance of substation equipment must be scheduled in coordination with maintenance outages of the nuclear units.

#### *C. Intelligent interlocking system based on the measured voltages and currents*

Based on the topology it is possible to determine for each item of equipment whether it is permissible to switch it or not. This function sends updated information to the operator and sends warning messages if conflicts are detected between the topology and the built-in interlocking mechanism. This mechanism works with logical equations.

#### *D. Diagnostics of disturbances, determination of the places and types of short-circuits, and advising in recovery procedures*

When an error/disturbance situation occurs the SCADA system sends many error and warning signals to the operator, and it is very difficult for the operator to quickly determine the real reason of those signals. Typically many changes occur within an interval of 10-100 ms. The advisory system detects the changes in proper order, and tries to fit the predefined "protection samples" with a kind of tolerance and finally informs the operator about the best fitting sample. Earlier this information was available only several hours or even days later, when the engineering team analyzed recordings made by the (analog) measurement equipment.

The table below (Table 1.) gives a part of one of these protection samples.

In the knowledge acquisition phase of the project about 200 different disturbance events were collected (presently only in the 400 kV part of the substation). The table shows a protection sample defined by the technology expert of the substation. It is a meta sample which means that it defines 3 X 3 different samples (3 fields - 400/2, 400/3, 400/5 and the 3 phases - R, S, T). This table describes the logical connections among the signals, the importance of them, and the format of the signals (e.g. 0->1->0). For each sample there are "forbidden" signals defined, which means that if such a signal exists among the collected data then that sample must not fit.

The fitting algorithm first selects those samples for which all "key" signals exist and no "forbidden" signal is present among the collected data. It then classifies the samples as to how well they fit with the other (important, non-important and extra) signals. In the next step the refinement is done, comparing the timing context of the samples and the elements of the collected data set.

Fig. 3. shows the representation of the protection sample given above in G2 as a graph where the relationship among the signals can be seen as well. It is an unsuccessful attempt to reclose a circuit breaker after a short circuit near the other end of a 400kV-transmission line.

In the realization of this function procedural and rule based methods were mixed. The trigger of the function and most of the data processing is coded in procedures but a set of rules should fire to determine which is the most fitted sample.

Each protection sample includes the information about the current peak load (e.g. full, half, quarter or normal) of every circuit breaker that plays a role in the sample. The best-fitted sample defines the maintenance message that is sent to the maintenance design staff.

#### *E. Automatic generation of switching sequences*

The operator should plan the switching sequence of the equipment when such a command comes from the nuclear plant operators or from the control center of the Hungarian Electric Board. The user interface of the command selection function was designed for operators unskilled in computer science.

Sample name	Field range	Serial Num.	Signal	Sign type	Sign value	Last sign	Time rel.	Time tol+	Time tol-	Importance	Maint.
910%_TVFSZFNVS	2,3,5	1	910%_KT	M	D	8	80	20	10	F	IF
910%_TVFSZFNVS	2,3,5	2	910%_ÖT	M	D	8	80	20	10	F	IF
910%_TVFSZFNVS	2,3,5	3	910%_KT	M	B	16	100	20	20	F	
910%_TVFSZFNVS	2,3,5	4	910%_ÖT	M	B	16	100	20	20	F	
910%_TVFSZFNVS	2,3,5	5	910%_KT	M	K	18	80	20	10	F	IF
910%_TVFSZFNVS	2,3,5	6	910%_ÖT	M	K	18	80	20	10	F	IF
910%_TVFSZFNVS	2,3,5	7	910%_TV1\$E	\$	F					F	
910%_TVFSZFNVS	2,3,5	8	910%_TVA1O	V	F	0	44	5	5	F	
910%_TVFSZFNVS	2,3,5	9	910%_KT\$AVO1	\$V	F	0	44	5	5	F	
910%_TVFSZFNVS	2,3,5	10	910%_ÖT\$AVO1	\$V	F	0	44	5	5	F	
910%_TVFSZFNVS	2,3,5	11	910%_TV2\$E	\$	F					F	
910%_TVFSZFNVS	2,3,5	12	910%_TVA2O	V	F	0	58	20	20	F	
910%_TVFSZFNVS	2,3,5	13	910%_KT\$AVO2	\$V	F	0	60	20	20	F	
910%_TVFSZFNVS	2,3,5	14	910%_ÖT\$AVO2	\$V	F	0	60	20	20	F	
910%_TVFSZFNVS	2,3,5	15	910%_TV2FZI	J	F					K	
910%_TVFSZFNVS	2,3,5	16	910%_VA	A	F	20	2000	200	200	K	
910%_TVFSZFNVS	2,3,5	17	910%_SY1V	J	F	0	64	10	10	K	
910%_TVFSZFNVS	2,3,5	18	910%_TVA1O	V	F	16	44	5	5	F	
910%_TVFSZFNVS	2,3,5	19	910%_TVA2O	V	F	16	58	20	20	F	
910%_TVFSZFNVS	2,3,5	20	910%_TV2\$E	\$	M	1	40	30	20	N	

Table 1. Predefined protection samples

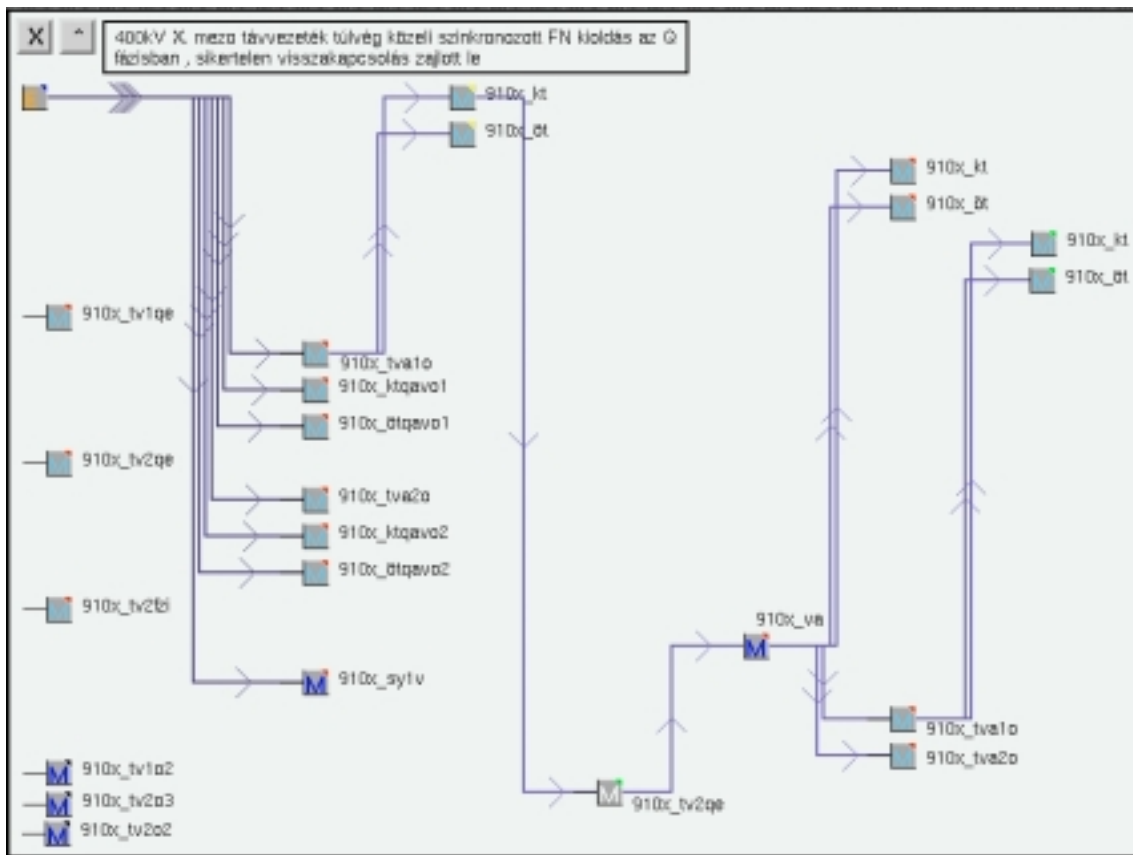

Figure 3. Representation of a protection sample in the G2 system

[“400 kV line, in the X field, was deenergized to clear a short-circuit fault. Attempted reclosure was not successful.”]

The starting state of the function is the present state of the substation. The final state is automatically calculated from the command and the present state. The switching sequence should be automatically generated using basic electrical rules and the special custom rules followed at Paks. The generated sequence is printed for the operator, who has to check and sign it, then execute it manually. Fig. 4. gives a list of these commands and some examples.

The algorithm defines step by step the sequence of elements to be switched. It uses the SCADA system's built in interlocking equations and invokes the rules of the experts. The knowledge acquisition process by which the rules given by the experts are represented is done very easily in the G2 [3] code. In the following lines these rules are illustrated-one electrical and two custom rules in switching-off commands:

- for any disconnecter  $D$  in SWG-LIST if there exists a circuit-breaker in SWG-LIST then remove  $D$  from SWG-LIST
- for any 400-line-disconnector  $LD1$  in SWG-LIST if there exists a 400-line-disconnector  $LD2$  in SWG-LIST such that ( the branch of  $LD2 =$  the symbol  $br\ddot{o}$ ) and  $LD1$  is not the same object as  $LD2$  then remove  $LD1$  from SWG-LIST
- if there exists a  $sf6$ -line-disconnector  $LD1$  in SWG-LIST such that ( is-contained-in-text ("\_BS", the text of the names of  $LD1$  ) = true ) and there exists a  $sf6$ -line-disconnector  $LD2$  in SWG-LIST such that ( is-contained-in-text ("\_BÖS", the text of the names of  $LD2$  ) = true ) then remove  $LD2$  from SWG-LIST and conclude that SWG-NXT = the names of  $LD2$

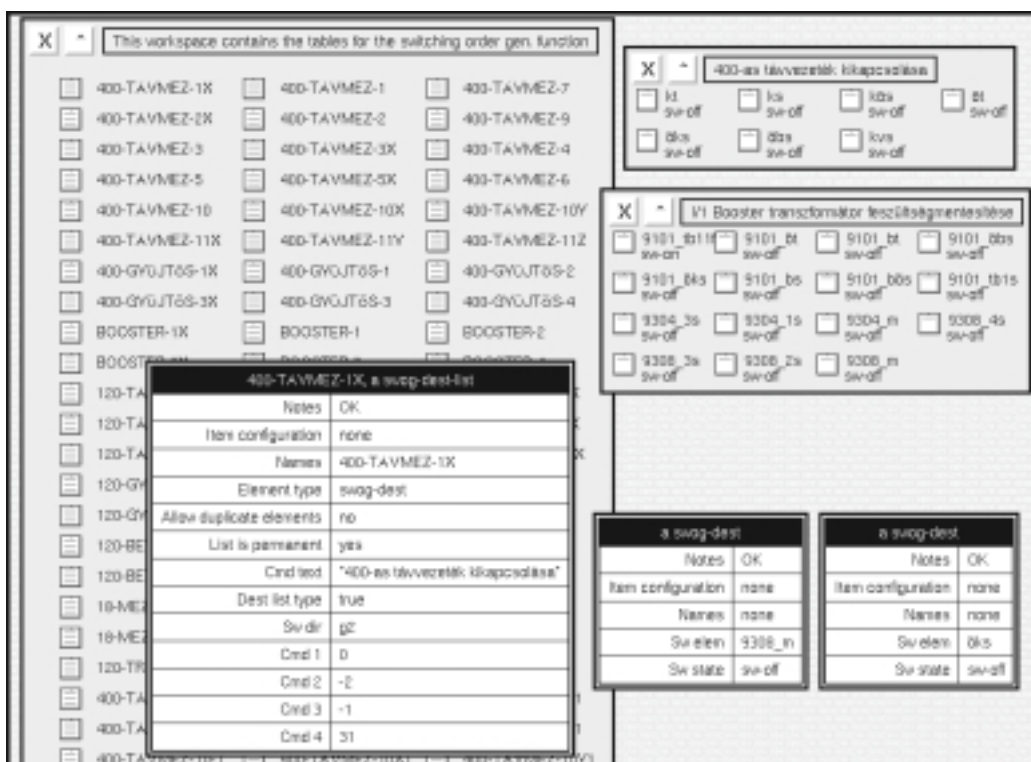

(Note: The titles of the workspaces (windows) on the right are "400 kV line switch off" and "I/1 Booster Transformer removed from voltage".)

Figure 4. A list of some switching sequence generation commands and some examples

#### IV. HARDWARE-SOFTWARE ENVIRONMENT

To realize this complex system, the G2 Intelligent Real-Time System [3] was chosen because of the following reasons:

- Its capability of handling very different type of data and information processing methods
- Real-time and object oriented features
- Good, easy to use graphical development tools
- Easy to understand and easy to use, English-like programming language
- Support of cyclic development (e.g. rapid prototypes)
- Relatively easy interfacing to different external systems (e.g. SCADA, SQL)

- More than 6000 industrial references all over the world including power plant sites ([5],[6],[7],[8])
- 5 years experience in design and programming of G2 at SzTAKI

The hardware-software environment of the whole system is the following:

- Server: MS WinNT Server to run FIX SCADA, MS SQL, G2
- Operator Station: MS WinNT WS to run the FIX SCADA Display. The G2 messages and displays are included in the operator's SCADA station.
- Engineer Station: MS Win NT/95/98, Gensym's Telewindows [4]

## V. SOME SOFTWARE IMPLEMENTATION ISSUES

As a FIX-based (Intellution) SCADA system was implemented at the substation [2] we had to be connected to the information sources of it, as the SCADA system is connected to all external data of the system. This way an intensive use of GSI was necessary to get and send SQL data and FIX specific ODB and EDA data, etc. Moreover for certain functions individual C language I/O programs had to be written and integrated to the whole system. As the requirements of the SCADA system were fixed before we started the G2 development we had to keep ourselves to the SCADA screen designs in general and with all elements of G2 on the screens, too. Thus a completely SCADA-like set of G2 windows serves the plant engineer to evaluate and analyze past events, and to prepare decisions for the future, and a restricted number of SCADA-like G2 windows assist the operator for decision making.

## VI. CONCLUSIONS

An intelligent, multi-function advisory system was implemented and introduced which supports the operators and plant engineers in the 400/120 kV substation of the Paks Nuclear Power Plant. The different but closely coupled functions were briefly explained.

Functions based on our experience at Paks could be used in other (similar) substations, as well. The hardware-software environment (G2-SCADA-SQL architecture) is the same as in the plant computers at Paks, so that many future applications where intelligent information processing is needed could be developed using the experiences of this project.

This project is also the first industrial application of G2 in Hungary.

## VII. ACKNOWLEDGEMENT

The project was sponsored and assisted by the Paks Nuclear Power Plant Ltd. The contributions of Eurocom Ltd., as system integrator of the SCADA system, Erőterv Ltd. as domain expert are accepted and highly appreciated.

## VIII. REFERENCES

- [1] Hungarian Electricity Production, <http://www.npp.hu/Eng/villena.html>
- [2] Eurocom Ltd.: Local information control system, Helyi Irányító Rendszer, System Books, 1998, in Hungarian
- [3] G2 Reference Manuals, Gensym Corp. 1998, <http://www.gensym.com>
- [4] Telewindows Reference Manuals, Gensym Corp. 1998,
- [5] ABB Power Plant Control based on G2, <http://www.gensym.com.successtories/abbpower.html>
- [6] Doble Test Assistant&trade (DTA) Software, <http://www.doble.com/doble/marketing/dta.html>
- [7] Rosenof, H. P.: A Spot Market for Electricity, <http://www.gensym.com.successtories/powerauc.html>
- [8] Delfino, B. et al.: Enhancing Flexibility of Restoration Guidelines Through an Integrated Simulator-KB Approach, Power Tech Conference, Stockholm, Sweden, June 18-22, 1995, pp. 129-133
- [9] Tolvéd at ELMU Rt., <http://www.dynadata.hu/text/appe.html>